

MagnetoSpeed

Sporter Ballistic Chronograph

For barrel diameters: 0.5" – 1.0"

Muzzle brakes up to 2.7" in length

Parts List

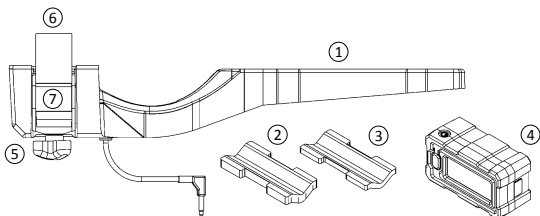

1	Bayonet (Bayo)
2	Thick Rubber Spacer
3	Thin Rubber Spacer
4	Display
5	Thumb Nut
6	1" Cordura Strap
7	Cam Buckle

Quick Start Guide

Mount it

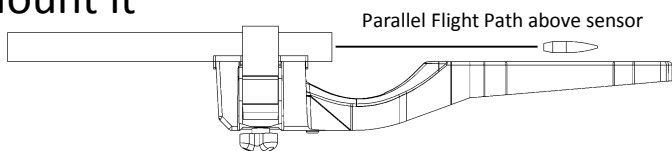

- With thumb nut loosened to end of threads, slip strap over barrel and pull strap tight through cam buckle then tighten thumb nut firmly
- Double check that spacing is good and bullet will travel in a parallel path above the sensor (tapered barrels will introduce a slight angle which is OK)

Connect it

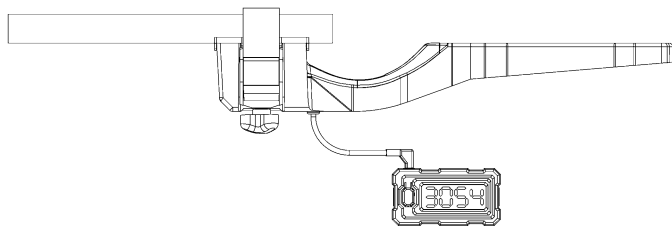

- Plug in cable to display, this will turn the display unit on
- Display will go through startup sequence and when - - - - is displayed, unit is ready to record shots

Ready to take data...Under most circumstances your chronograph should be ready to shoot over and record data

Note: Read full instructions before operating

Strapping the Bayonet (Bayo)

- Seat muzzle end of barrel in V-block groove under strap. Use thicker rubber pad for thin-walled barrels
- Make sure sensor deck is down-range from muzzle.
- Make sure muzzle is 0.25-2.0 inches down-range from front of V-block (overhanging into blast zone).
- Make sure Thumb Nut is "unscrewed" almost all the way but still attached to end of Strap Screw.
- Pull cinch strap up through strap adjuster until ALL slack is taken up around barrel.
- Tighten Thumb Nut against Screw Frame until tight.
- Test grip of strap by tugging on the bayo; if unmovable then proceed. If not, continue tightening Thumb Screw.
- Remove bolt from gun (if possible) and look down the barrel towards the muzzle; make sure the bayo sensor deck cannot be seen through barrel to ensure bullet will not encounter bayo. **MAKE SURE BAYO SENSOR DECK IS NOT IN THE PATH OF THE BULLET!**
- Plug data cord into display unit jack. Continue to check muzzle location with reference to the V-block. If bayo is creeping off, retighten strap with muzzle in proper position.
- To remove, simply unscrew Thumb Nut to let off tension, pull back strap adjuster, slide off muzzle.
- Note: Loose strap end can be placed in strap collector slot in Screw Frame during storage/use.

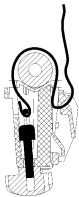
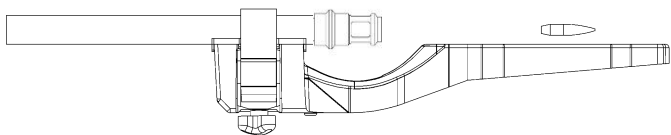

- Loose strap. Thumbscrew at bottom of threads.



- Thumbscrew tightened, with strap tucked in strap keeper.

Dimensions

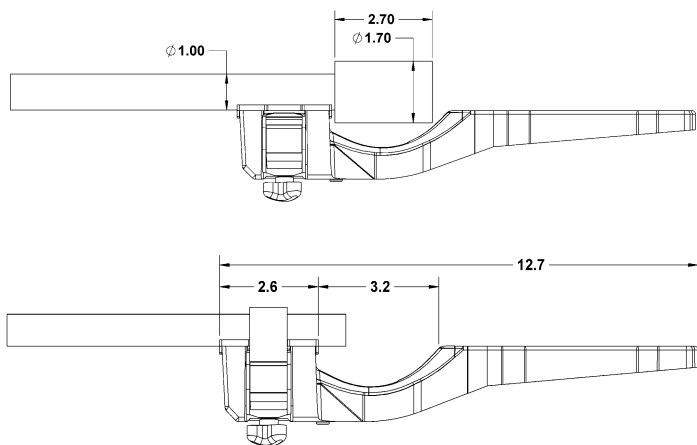

Disclaimer: The bayo is designed to fit tapered and bull barrel muzzles between 0.50 and 1.00 inches in diameter. It is the responsibility of the user to make sure that the bayo is mounted correctly with the sensor deck away from the bullet path.

Display Operation

- To turn display on, plug cable into the jack on top of the display
- This display is a 7 segment display, so refer to the guide word key
- The display will cycle through a startup sequence that displays the following, and the current settings
 - Firmware version
 - Battery voltage (ex. 8.8)
 - Sensitivity: *REG*(Regular) *HI 1* (High 1) or *HI 2* (High 2)
 - Units: *FPS* (Feet per sec) or *MPS* (Meters per sec)
- The unit will then arrive at the Home Screen



Home Screen with no shots
Ready to record new shots

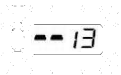

Home Screen with 13 shots
Ready to record, will add to current shot string

•To change sensitivity, from the Home Screen hold down the button until “Conf” flashes. Release the button. The current sensitivity setting will be displayed. Hold down the button again, until “done” is displayed. The sensitivity settings will change in the order of Reg, HI 1, then HI 2. To go from Reg to HI 2, you would have to cycle the sensitivity setting twice. After a change of sensitivity the display will flash the new setting. At any point if the button is not pressed for 20 seconds, the display will return to the home screen.

•To change units of measure, hold down the button while plugging unit in. After “Conf” flashes, release button. Current units will be displayed. Hold down button until “done” is displayed to cycle between FPS and MPS. Display will return to home screen after 20 seconds.

Troubleshooting

Check Sensor Spacing

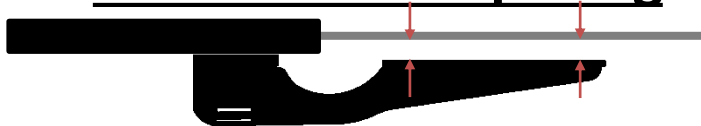

Use a cleaning rod to check the spacing of sensor 1 and sensor 2 from bottom bullet edge. Distances should be between 1/8" and 0.375" and they should be within 1/16" of each other.

Common Issues

- Lean in

- Bayo damage
- Reduced velocity accuracy



- Lean out

- Shot pickup error
- Reduced velocity accuracy

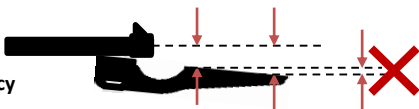

- Thick muzzle/barrel

- Low signal
- Reduced velocity accuracy
- Shot pickup error



- Muzzle too close to Sensor 1

- Signal gets noisy
- Reduced velocity accuracy
- Shot pickup error



- V-block overlaps muzzle

- Bayo/strapping damage



Magnetospeed, LLC

9206 Rod Rd, Suite C
Austin, Texas 78736

(512) 284-8161

info@magnetospeed.com

www.MagnetoSpeed.com

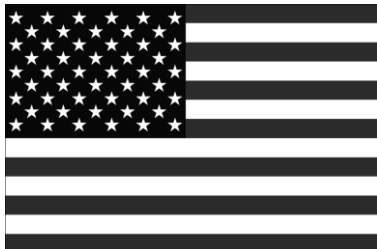

Made in USA
Patent Pending

